

INSTRUCTIONS FOR USE FACE GEARBOXES

TNC



MTC-TC



KTM

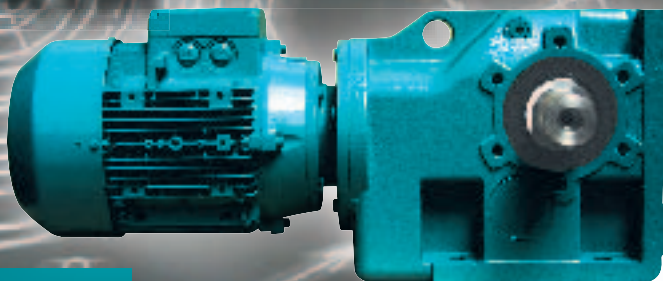



CERTIFICATE

The TÜV CERT Certification Body
of TÜV Management Service GmbH

certifies in accordance
with TÜV CERT procedures that

TOS ZNOJMO, akciová společnost
Družstevní 3
CZ-669 02 Znojmo

has established
and applies a Quality System for

**Development, Design, Manufacture, Distribution
and Service of Gearboxes, Geared Motors and
Drives, Production of Mechanical Parts**

An audit was performed, Report No. 70033750

Proof has been furnished that the requirements
according to

ISO 9001 :2000

are fulfilled. The certificate is valid until December 2005

Certificate Registration No. 12 100 17839

March, December 15, 2002



TÜV
MANAGEMENT SERVICE

TÜV CERT Certification Body
of TÜV Management Service GmbH
Unter den Eichen, Gruppe TÜV Südwestfalen



ES – Declaration of Conformity

Producer: TOS ZNOJMO, akciová společnost
Družstevní 3
CZ – 669 02 Znojmo

Equipment: Face gearboxes

Type/ Modification: MTC, TC 11, 21, 31, 41
MTC, TC 02, 12, 22, 32, 42, 52, 62, 72
MTC, TC 23, 33, 43, 53, 63, 73

Equipment description: The products have been designed to drive other equipment. The gearbox is connected with another equipment through a hollow shaft or an output shaft with a full shaft. The MTC modification includes el. motor, the TC modification has not any motor.

The equipment fulfils all relevant provisions of:

- ministerial order No.170/1997 of Code, in the wording of the ministerial order No.15/1999 of Code, ministerial order No. 283/2000 of Code and the ministerial order No. 251/2003 of Code (complies with the regulation 98/37/ES)
- standards: ČSN EN 292-1:2000, ČSN EN 292-2+A1:2000, ČSN EN 294:1993, ČSN EN 614-1:1997, ČSN EN 953:1998, ČSN EN 1037:1997,

Consideration of conformity has been effected by the deposition of the documentation in manufacturer's files:

- according to § 12 of the article 3, letter a) of the Law 22/1997 of Code, valid wording and § 3 of the article 1, letter a) of the ministerial order No. 170/1997 of Code in the wording of later regulations.

We hereby declare the equipment is safe when applied in compliance with the design purpose. The manufacturing procedure accepts and performs all provisions providing conformity of all machinery introduced to the market with technical documentation and principal requirements.

Znojmo, 1st March 2004

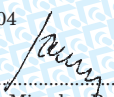
.....
Ing. Miroslav Pavlas
Member of the Board of Directors

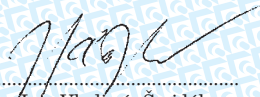
.....
Ing. Vladimír Šmidák
Chairman of the Board of Directors

The present declaration does not guarantee the qualities within the sense of responsibility of the product. Safety regulations specified in the product documentation must be adhered to.



ES – Declaration of Conformity

Producer: TOS ZNOJMO, akciová společnost
Družstevní 3
CZ – 669 02 Znojmo

Equipment: Face gearboxes

Type/ Modification: TNC 12, 22, 32, 42, 52
TNC 13, 23, 33, 43, 53

Equipment description: The products have been designed to drive other equipment. The gearbox is connected with another equipment through a hollow shaft or an output shaft with a full shaft.

The equipment fulfils all relevant provisions of:

- ministerial order No.170/1997 of Code, in the wording of the ministerial order No.15/1999 of Code, ministerial order No. 283/2000 of Code and the ministerial order No. 251/2003 of Code (complies with the regulation 98/37/ES)
- standards: ČSN EN 292-1:2000, ČSN EN 292-2+A1:2000, ČSN EN 294:1993, ČSN EN 614-1:1997, ČSN EN 953:1998, ČSN EN 1037:1997,

Consideration of conformity has been effected by the deposition of the documentation in manufacturer's files:

- according to § 12 of the article 3, letter a) of the Law 22/1997 of Code, valid wording and § 3 of the article 1, letter a) of the ministerial order No. 170/1997 of Code in the wording of later regulations.

We hereby declare the equipment is safe when applied in compliance with the design purpose. The manufacturing procedure accepts and performs all provisions providing conformity of all machinery introduced to the market with technical documentation and principal requirements.

Znojmo, 1st March 2004

.....
Ing. Miroslav Paylas
Member of the Board of Directors

.....
Ing. Vladimír Šmidák
Chairman of the Board of Directors

The present declaration does not guarantee the qualities within the sense of responsibility of the product. Safety regulations specified in the product documentation must be adhered to.



ES – Declaration of Conformity

Producer: TOS ZNOJMO, akciová společnost
Družstevní 3
CZ – 669 02 Znojmo

Equipment: Angle-face gearboxes

Type/ Modification: KTM 43, 53, 63

Equipment description: The products have been designed to drive other equipment. The gearbox is connected with another equipment through a hollow shaft or an output shaft with a full shaft.

The equipment fulfils all relevant provisions of:

- ministerial order No.170/1997 of Code, in the wording of the ministerial order No.15/1999 of Code, ministerial order No. 283/2000 of Code and the ministerial order No. 251/2003 of Code (complies with the regulation 98/37/ES)
- standards: ČSN EN 292-1:2000, ČSN EN 292-2+A1:2000, ČSN EN 294:1993, ČSN EN 614-1:1997, ČSN EN 953:1998, ČSN EN 1037:1997,

Consideration of conformity has been effected by the deposition of the documentation in manufacturer's files:

- according to § 12 of the article 3, letter a) of the Law 22/1997 of Code, valid wording and § 3 of the article 1, letter a) of the ministerial order No. 170/1997 of Code in the wording of later regulations.

We hereby declare the equipment is safe when applied in compliance with the design purpose. The manufacturing procedure accepts and performs all provisions providing conformity of all machinery introduced to the market with technical documentation and principal requirements.

Znojmo, 1st March 2004

.....
Ing. Miroslav Pařlas
Member of the Board of Directors

.....
Ing. Vladimír Šmidák
Chairman of the Board of Directors

The present declaration does not guarantee the qualities within the sense of responsibility of the product. Safety regulations specified in the product documentation must be adhered to.

Content

INSTRUCTIONS FOR USE SERVICE AND MAINTENANCE OF GEARBOXES

CHAPTER	PAGE
1 Application	5
2 Technical data	5
3 Safety	8
4 Noise emission.....	10
5 Transport	10
6 Preservation removal	10
7 Mounting	10
8 Lubrication, troubleshooting.....	11
9 Storage.....	13
10 Spare parts.....	13
11 Scrapping and disposal	15
12 Guarantee	15
Acceptance Certificate	17



Instructions for use – service and maintenance MTC/TC – TNC – KTM gearboxes

1) Application:

The face and angle-face gearboxes have been designed to drive **other equipment**. A MTC-TC gearbox is generally connected with another equipment through an output shaft. TNC and KTM gearboxes are connected through an output hollow shaft or a slip-on full shaft.

The gearbox provided with an el. motor can be installed and operated at workplaces complying with the ČSN EN 60 204-1 standard – Electrical equipment of machinery: Part 1: General Requirements.

2) Technical data:

Each gearbox is provided with a name plate.

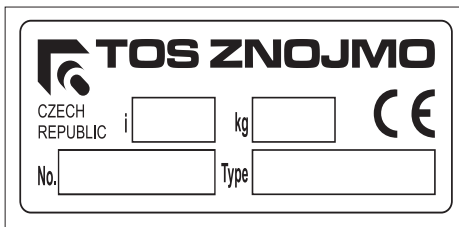

Type: gearbox type

kg: gearbox mass

No: Serial No.

i: gear ratio

The name plate shown in the figure includes also identification data, which shall be specified anytime you contact our commercial or technical department.

MTC, TNC and KTM types: gearboxes with hollow input shaft together with a flange for the mounting of motor or another assembly with a flanged equipment according to IEC. To achieve compact design the application of motor of IM B14 (IM 3681) design is used as much as possible.

TC, TNC and KTM types: gearbox with a full shaft both on inlet and outlet ends

TNC and KTM types: gearboxes with a hollow output shaft



Table 2.2. Design and mounting positions for MTC/TC (without motor)







 B3	1	 B6	4	 B7	7
 B8	2	 V5	5	 V6	8
 B5	3	 V1	6	 V3	9

Table 2.2. Design and mounting positions for TNC

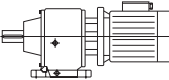

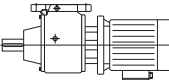
 1	 2	 4
 5	 6	 7

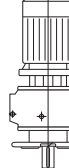
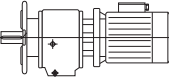
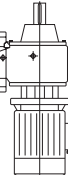

Table 2.2. Design and mounting position for KTM

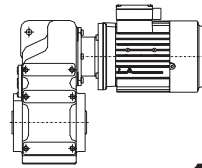
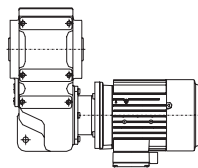
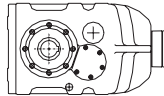
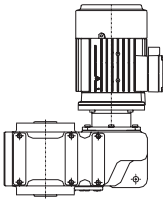
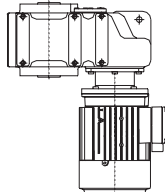

Material applied:

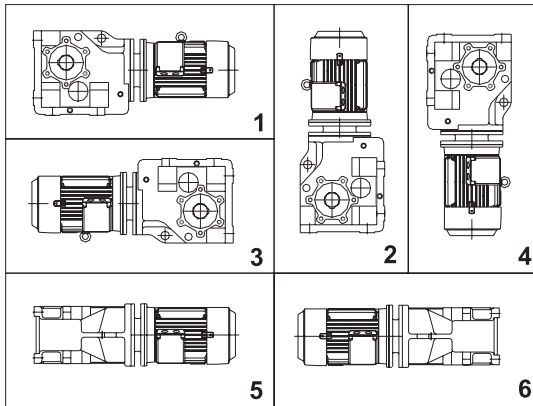
- iron parts – cast iron ČSN 422420
- gear wheels and shafts – engineering steel – thermal treated
- bearings – SKF or equivalent
- flange dimensions – for mounting according to IEC 72 standard
- lubrication – synthetic oil
- surface finish – polyurethane paint
- shaft sealing – NBR material, WAS type
- input shaft – dimensions according to IEC 72 standard
- output shaft – dimensions according to IEC 72 standard, thread according to DIN 332 DS
- flanges of motor – aluminium alloy

Table 2.1 (9.1 catalogue)

Flanges dimensions according to IEC 72				
M	P	N	FF S	FT S
65	80	50	5,8	M5
75	90	60	5,8	M5
85	105	70	7	M6
100	120	80	7	M6
115	140	95	10	M8
130	160	110	10	M8
165	200	130	12	M10
215	250	180	15	M14
265	300	230	15	M14
300	350	250	18,5	M16

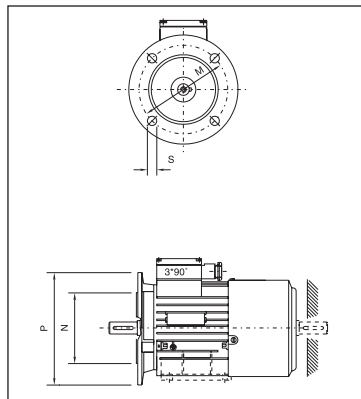



3) Safety:

The gearbox **must** be fixed to a solid base. Rotary parts **must** be protected with a safety cover and provided with warning identification. The gearbox **may not** be overloaded. In case of overload danger during start, shocks or blocking a safety clutch **must** be provided. Radial load F_{rad} **shall not be exceeded** at the outlet shaft, see the Table 4.1, page 8.

Table 4.1 Max. permissible radial and axial load

one stage					two and three stage							
MTC TC	11	21	31	41	MTC TC	02	12	22/23	32/33	42/43	52/53	62/63
n [min ⁻¹]	Fr [N]	Fr [N]	Fr [N]	Fr [N]	n [min ⁻¹]	Fr [N]	Fr [N]	Fr [N]	Fr [N]	Fr [N]	Fr [N]	Fr [N]
600	750	1200	1820	3500	300	640	860	940	2940	3580	4820	8210
450	830	1320	2000	3860	250	680	920	1000	3100	3780	5100	8680
400	860	1370	2080	4010	200	740	990	1080	3320	4040	5450	9280
350	900	1440	2180	4200	150	810	1080	1190	3620	4400	5940	10110
300	950	1510	2290	4420	100	930	1240	1360	4080	4970	6710	11420
250	1010	1610	2440	4690	80	1000	1340	1460	4370	5320	7170	12210
200	1090	1730	2630	5060	60	1100	1470	1610	4760	5800	7820	13310
150	1200	1910	2890	5570	40	1260	1690	1840	5380	6540	8830	15040
					20	1580	2120	2320	620	8060	10870	18510

two and three stage						three stage			
TNC	12/13	22/23	32/33	42/43	52/53	KTM	43	53	63
n [min ⁻¹]	Fr [N]	Fr [N]	Fr [N]	Fr [N]	Fr [N]	n [min ⁻¹]	Fr [N]	Fr [N]	Fr [N]
300			3600	4900	8300	200	11000	6300	12000
250			3800	4900	8300	150	11000	6300	12000
200	3200	2600	4200	5800	8600	100	11000	6600	12000
150	3100	2600	4300	5800	8600	80	12000	7000	12000
100	3600	2400	5000	5900	8400	60	12000	7800	12000
80	3800	3000	5200	6000	7800	40	13000	8500	13000
60	4100	3400	5700	6000	12000	30	13000	9400	16000
40	5000	3300	5800	6500	12000	20	13000	10000	22000
30	5100	4400	6500	7500	12000	10	13000	14000	27000
20	5300	5300	10000	11000	12000	5	13000	15000	30000

Radial load F_{rad} : a half of the slip-on full shaft (see the Figure 3.1, page 9) is considered the origin of radial force F_{rad} for the determination of this value. If the radial force on the shaft acts within a longer distance, max. permissible load **must** be reduced. E.g. only 80% of the value shown in the table is acceptable for the loading in the point of 75% of the full shaft. Load higher by 25% can be allowed for the load in the point of 30% of the full shaft length. If pulley, chain wheel or gear wheel, etc. is installed on the outlet shaft, the radial load can be determined from the following formula and the Figure 3.1 (page 9):



$$F_{rad} = \frac{T_2 \times k \times 2000}{D}$$

- F_{rad} = radial load [N]
- T_2 = output torque [Nm]
- D = rated diameter of pulley (pitch circle) [mm]
- k = load factor
 - 1,2 for chain wheels
 - 1,25 for front gear wheels
 - 1,5 for pulleys

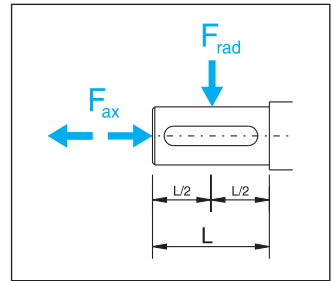

Fig. 3.1

It means the radial load of the shaft can be decreased by increasing the pulley diameter, if possible. If radial load is still high or the force acts on the full shaft within long distance, external support in bearings **must** be applied for the transfer of forces.

Axial load F_a max with $F_x = 0$

Permissible load of the hollow shaft:

$$F_{ra} = F_r - 3 F_a \text{ [N]}$$

- $F_{a \max}$ [N] – max. permissible axial force
- F_r [N] – allowable radial value is specified in the Table 4.1, page 9

Radial load of the shaft with simultaneous application of axial force

With simultaneous application of axial and radial forces the load of shafts shall not exceed

$$F_{a \max} = \frac{F_r}{3} \text{ [N]}$$

- F_a [N] – axial load of the shaft
- F_r [N] – allowable radial load value specified in the Table 4.1
- F_{ra} [N] – max. permissible radial force with simultaneous application of the axial force F_a [N]



Method of the gearbox interconnection to machinery by means of a pulley or a chain wheel

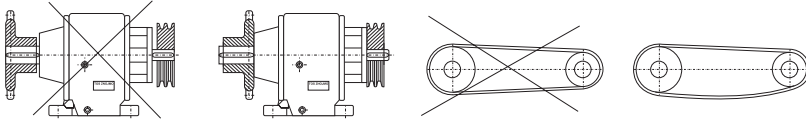

4) Noise Emission:

acoustic pressure level A, when using A balance filter, does not exceed 70 dB. Measured according to ČSN EN 60034-9, ČSN ISO 3740, ČSN ISO 3744 and ČSN ISO 3746 standards.

5) Transport:

gearboxes are generally delivered in wooden casing, provided with KORING preservation for 3 months and are fixed to prevent undesirable movement in the casing. Prevention against vibrations or fall is necessary. Check the package properly **prior to opening** to identify prospective damage. Check if the gearbox was not damaged during transport immediately when delivered. If so record together with the forwarder the range of the damage in a protocol. Inform the gearbox seller or producer at once.

6) Preservation Removal:

is not required. In case the gearbox has been sprayed with a varnish, preservation shall be removed with an agent which **must not** damage rubber packing or previous layer of varnish.

7) Mounting:

The following shall be kept while installing the gearbox and putting it into operation:

- outer vibrations and high ambient temperature shall not occur, any obstacles preventing air flow as well as heat sources shall be removed from the gearbox vicinity
- protective switches and clutches shall be applied in case of load with shocks. If such provisions are neglected, the gearbox could be damaged
- connected aligned shafts and clutches shall be assembled in accordance with respective instructions for use of the supplier of clutches
- the holes of parts at the end of the output shaft require H7 tolerance and shall be locked with feathers
- diameters of shafts slip-on in the hollow shaft require H7 tolerance
- matched surfaces shall be perfectly cleaned and protected against seizing and corrosion prior to assembly
- the gearbox shall be mounted on a flat, finished surface or just slip-on on the output shaft and torque shall be transferred to the support
- parts slip-on on the shaft shall be threaded at the shaft front side



- gearboxes shall be protected against solar radiation and extreme weather effects
- oil filling shall be checked in accordance with the Acceptance Certificate (page 17) – gearboxes without lubricant – filled as required – see the Table 8.3, page 12
- the connecting shaft shall be inserted into the hollow shaft and locked along its whole length
- transport plug of a gearbox shall be replaced with a bleeder screw
- gear unit conditions shall be checked visually once per 24 hours at least
 - a) lubrication leakage – proper function of oil seal – replace a faulty one
 - b) fouled surface of the gearbox – remove impurities
- gearboxes which were out of operation for a long period shall be treated according to the instructions of the chapter on **storage**

8) Lubrication and Troubleshooting:

NOTE: The kind of oil filling is specified in the Acceptance Certificate – page 17. The gearboxes are generally delivered with filling; if required they are delivered without filling.

Shaft seal – the shaft seal is replaced if damaged and does not fulfil its function.

Lubricant replacement – the gearboxes are filled with synthetic oil. They are filled with mineral oil if required by the customer. Mineral oil shall be replaced for the first time after 400 working hours, then by each 4000 hours.

Synthetic and mineral lubricants **must not** be mixed. When another kind of lubricant is intended to be used, the gear unit shall be cleaned unconditionally.

Table 8.1 (12.1 catalogue) Lubricating intervals – hours

Temp [°C]	load	mineral oil	synthetic oil
< 60	permanent	4000	long-term
< 60	intermittent	6000	
> 60	permanent	2000	
> 60	intermittent	4000	

Lubricant replacement procedure – drain the lubricant heated by operation, clean the gearbox with a flushing agent which **shall not** be aggressive to rubber packing of the shaft and to the varnish. Dry the gear unit and fill the lubricant, see the Table 8.3, page 12.



Table 8.2 Lubricants recommended

	mineral oil		synthetic oil	
ambient temp.	-10 °C – +50 °C		-20 °C – +50 °C	
load	normal	heavy	normal	heavy
OMV	Ole HST 220 EP	Ole HST 320 EP	Unigear S 75 W-90	
Agip	Blasia 220	Blasia 320	Blasia S	
Aral	Degol BG 220	Degol BG 320	Degol GS 220	
Castrol	Alpha SP 220	Alpha SP 320	Alpha SH 220	
ESSO	Spartan EP 220	Spartan EP 320		
Klüber	Lamora 220	Lamora 320	Syntheco HT 220	
Mobil	Mobilgear 632	Mobilgear 634	SHC 630	
Shell	Omala EP 220	Omala EP 320	Omala HD 220	
Optimol	Optigear BM 220	Optigear BM 320	Optigear A 220	
Total	Carter EP 220	Carter EP 320		
Paramo	Paramol CLP 220	Paramol CLP 320		

Table 8.3 Quantity of lubricant

One stage MTC/TC

amount	type	MTC/TC 11	MTC/TC 21	MTC/TC 31	MTC/TC 41			
lubricant [l]	B + V	0,3	0,5	0,5	1,1			

Two stage MTC/TC

amount	type	MTC/TC 02	MTC/TC 12	MTC/TC 22	MTC/TC 32	MTC/TC 42	MTC/TC 52	MTC/TC 62	MTC/TC 72
lubricant [l]	B + V	0,23	0,28	0,30	0,50	1,00	1,30	2,50	4,50

Three stage MTC/TC

amount	type	MTC/TC 23	MTC/TC 33	MTC/TC 43	MTC/TC 53	MTC/TC 63	MTC/TC 73	
lubricant [l]	B	0,45	0,50	1,00	1,50	2,50	4,50	
lubricant [l]	V	0,50	1,10	1,80	2,15	2,80	4,50	

TNC

amount	TNC 1_	TNC 2_	TNC 3_	TNC 4_	TNC 5_			
lubricant [l]	0,7	1,5	2,2	4,5	6			

KTM

	quantity of oil [l]								
Type	Pos. 1	Pos. 2	Pos. 3	Pos. 4	Pos. 5	Pos. 6			
KTM 43	1,6	2,9	2,4	2,2	2,6	2,6			
KTM 53	1,8	5,2	4,2	3,9	4,2	4,2			
KTM 63	2,5	9,6	8,5	7,6	7,5	7,5			



Troubleshooting:

Incorrect repairs could **cause** faulty function or damage of the gearbox. The producer performs skilled and post-guarantee repairs of the gearboxes.

9) Storage:

If a gearbox will be stored or out of operation for a longer period, it is important to **protect** its external surface against corrosion. Such preservation should be renewed according to its type and ambient environs. The store **must** be dustfree, dry and without vibrations. Storage rooms temperature **should** range within 0–40 °C: [± 10 °C] is permissible. **It is advised** to turn the shaft by min. one revolution once per 3 – 4 months. Gearboxes filled with oil shall be stored and transported in the mounting position. If a long-term storage period in the open air or in insufficient conditions is expected, producer's advice is **necessary**.

10) Spare parts:

with respect to required professional assembly and disassembly of the gearbox and special requirements on accuracy of the mounting, the manufacturer does not recommend any unskilled repairs of gearboxes. Therefore no spare parts are specified by the manufacturer. Only replacement of the shaft sealing rings is accepted (see chapter 8). When ordering shaft rings always specify the type identification of the gearbox and its serial number.

Spare parts for MTC_1

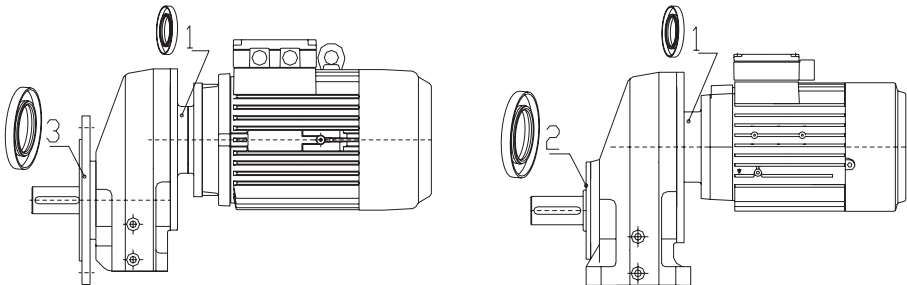

1. Shaft sealing ring for the motor
2. Shaft sealing ring for the output shaft
3. Shaft sealing ring for the output shaft in the flange



Spare parts for TNC

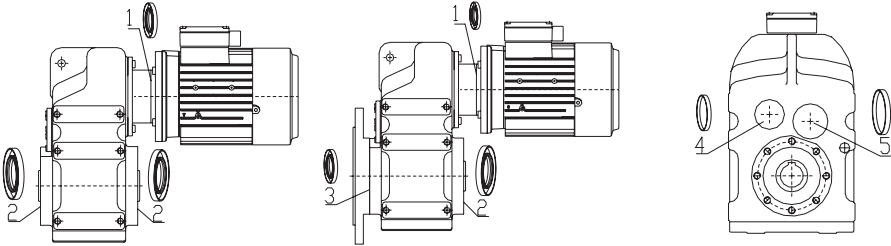

1. Shaft sealing ring for the motor
2. Shaft sealing ring for the hollow shaft
3. Shaft sealing ring for the hollow shaft in the flange
4. Small full cap
5. Small full cap (for sizes 1 and 2 only)

Spare parts for KTM

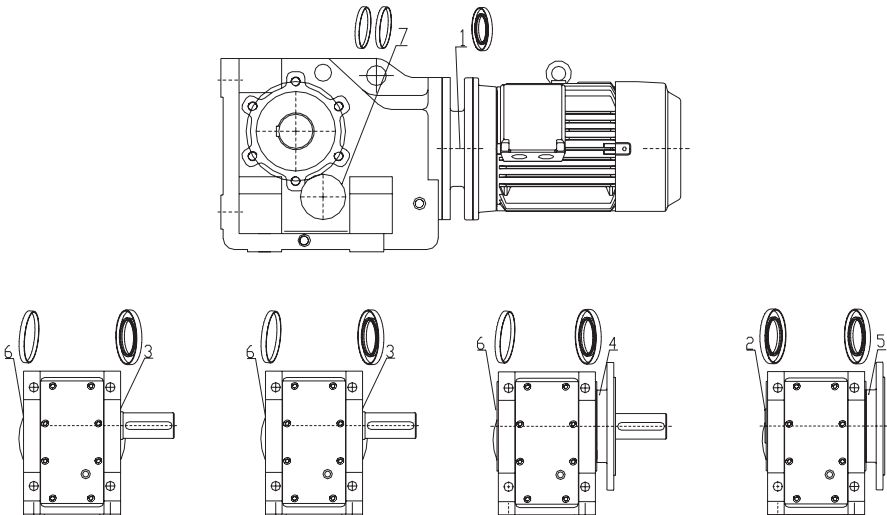

1. Shaft sealing ring for the motor
2. Shaft sealing ring for the hollow shaft
3. Shaft sealing ring for the output shaft
4. Shaft sealing ring for the output shaft in the flange
5. Shaft sealing ring for the hollow shaft in the flange
6. Small full cap for the output shaft
7. Small full cap for the box



11) Scrapping and Disposal:

After service life expiry gearboxes shall be scrapped in compliance with respective regulations and laws on waste, crude oil matters disposal to prevent threat of people and living environment. Disassemble the gearbox classify its parts according to their material, remove lubricant and deliver it to a specialised company for disposal

12) Guarantee:

The guarantee is provided according to valid provisions of the **Law No. 513/91** (of the Commercial Code) in the wording of later regulations.

Cancellation of guarantee: in case the gearbox is used in defiance of the "Instructions of Use" or incorrect intervention was carried out.

Final Quality Control shall comply with the ISO 9001:2000 directive and the quality manual.



Notes:



ACCEPTANCE CERTIFICATE

Job No.:
.....
.....
.....
.....
.....

Serial No.:
.....
.....
.....
.....
.....
.....

Lubricant:

Final Quality Control

Date:

Checked by: